

ClimaFlow

VentilationJet System

Instruction Manual

Original instructions

Contents

Installation **3**

- Installation requirements 3
- Noise and vibrations 3
- PPE 4

Disclaimer **5**

- Safety precautions 5
- Description of precautionary measures 6
- Handling 7
- Operations 8
- Installation 9
- Operating environment 10
- Storage 10
- Maintenance 11
- Lifting the VentilationJet 11

General Description of the VentilationJet System **12**

- The ClimaFlow Fan 12
- The VentilationJet 12
- The VentilationJet System 12

Technical Product Data **13**

- ClimaFlow Fan 13
- VentilationJet 13
- Included with delivery 13
- Inside the ClimaFlow box 14
- VentilationJet Components 15
- Control cable specifications 16
- Connectors 17

VentilationJet instructions **18**

- Placing the VentilationJet 18
- Secure the VentilationJet 18
- Optional closing strips 18
- Long closing strips 19
- Short closing strips 19
- Spokes & ClimaFlow Fan suspension 20
- ClimaFlow Fan - Type A 21
- ClimaFlow Fan - Type B 22
- Placing the ClimaFlow Fan cables 23

Additional info **24**

- Maintenance protocol 24
- Unblocking an obstructed fan blade 25
- Technical datasheets 26
- Fan efficiency datasheets 31
- Datasheets 36
- Svensson contact information 40

Installation requirements

Always use installation material provided by Beektech Industries B.V. Failure to do so may result in damage, reduced performance or failure. By using the installation materials provided and following the installation manual, the installation will be safe. The total weight of the jet and fan is 34 kg \pm 2 kg.

Do not add additional components or hang or tie anything on to the jet/fan. Doing so could cause the system to get unbalanced and start vibrating or remove the safety margin for the fan/jet assembly causing premature failure of the installation.

Always make sure that the indicated torque has been used to tighten the bolts. Bolt torque requirements are provided in the installation manual.

Noise and vibrations

When installing the VentilationJet or ClimaFlow Fan, always make sure it hangs straight (Gravity is considered the reference, any deviation more than 5° might result in uneven wear and pre-mature failure), failure in doing so might increase the vibrations in the fan/jet and causing excessive noise. Failure in making sure it hangs straight might also cause pre-maturely failure and mechanical wear that in turn also can increase the level of unwanted noise.

PPE is required when entering the service area of the VentilationJet System

Beektech Industries B.V. Recommends using the following PPE when servicing the Ventilation Jet System:

- **Eye Protection**
Always wear appropriate safety glasses or goggles to shield your eyes from potential hazards.
- **Ear Protection**
Utilize ear protection such as earplugs or earmuffs when servicing the VentilationJet System to mitigate exposure to noise.
- **Hand Protection**
Wear suitable gloves to safeguard your hands during servicing tasks. Choose gloves based on the specific requirements of the job.
- **Foot Protection**
Ensure your safety by wearing protective footwear, such as safety shoes or boots with steel toes, to guard against potential foot injuries.
- **Head Protection**
Use a safety helmet to protect your head when working with the VentilationJet System, especially in situations where there is a risk of head injury.
- **Fall Protection**
Adhere to fall protection measures as needed, depending on the specific servicing conditions. Ensure the use of appropriate safety equipment to prevent falls.

Safety Precautions

General

To ensure that the VentilationJet and ClimaFlow Fan are used safely, be sure that you read and understand the following precautions fully and use it only as directed. Make sure you understand those precautions before installing, connecting, operating, maintaining, or inspecting the fan. Follow all the precautions and directions given here.

Beektech Industries B.V. will not be liable for any accidents resulting in death, injury, or property damage due to improper usage of the ClimaFlow Fan and/or VentilationJet.

The fan has been designed and manufactured for built-in use in general industrial buildings, warehouses and greenhouses, and must not be used otherwise.

The ClimaFlow Fan must be installed at a minimum 4 meters above the ground. The height needs to be ensured for an area with a diameter of 4 meters as shown in figure 1.

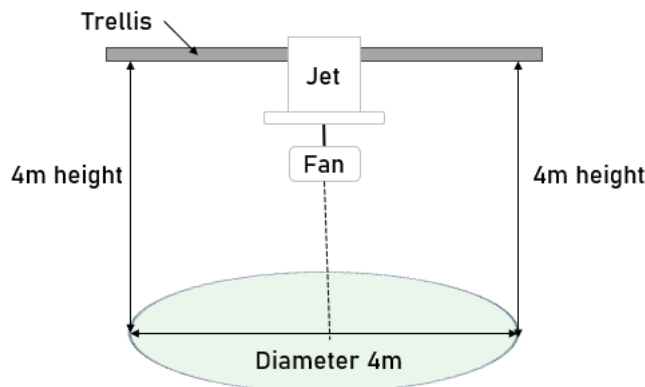

Figure 1 –ClimaFlow Fan and VentilationJet safety zone

When disposing the fan, treat it as industrial waste. For instructions on proper disposal methods, please contact local government authorities.

Description of precautionary measures

- Ensure that wiring is done correctly. Failure to do so might result in fire, burns, or electrical shock.
- Never use the mentioned equipment in explosive atmospheres, as doing so might result in fires, burns, or bodily injury.
- Do not operate the equipment with live parts exposed. Doing so might result in electric shock and injury.
- Never, while in operation, allow any persons or objects to approach or come into contact with the equipment, as doing so might result in damage or injury.
- Turn off the power and stop using the equipment immediately if you notice any sparks, smoke, odd odors, odd sounds, or anything unusual during operation. Failure to do so might result in fire, bodily injury or electrical shock.
- Turn the VentilationJet or ClimaFlow fan off, if a person or animal will enter the safety zone (figure 1) with any part of their body.
- Ear protection should be used if the VentilationJet is operational, and you are within the safety zone (figure 1)
- Never allow the fan to fall, topple over, or be subjected to excessive shocks when moving it. Doing so might result in product failure or performance deterioration. Beektech Industries B.V will not be responsible for any damages caused by those events
- The fan should be handled by technically qualified personnel with sufficient knowledge; the personnel shall be assigned at your own discretion.
- When doing any kind of maintenance work on the jet/fan or cleaning of the system, make sure the power is disconnected and that no potential remains in the system.
- The fan should be handled by technically qualified personnel with sufficient knowledge; the personnel shall be assigned at your own discretion.

Handling

- Installation, mounting, connections, wiring, and relocation of the jet/fan should be done by technically qualified personnel; the personnel shall be assigned at your own discretion. Make sure paragraph 2.6 and 2.9 are fulfilled.
- Do not operate the fan if it is not installed as intended.
- Never attempt to disassemble or alter the fan in any way. Doing so might not only result in substandard performance, but also fire, burns, bodily injury, or electrical shock.
- For maintenance work or when trouble shooting, make sure you have the correct instructions and make sure you follow all safety procedures
- Only lift the top plate extension strip



- Use the provided suspension materials to install the ClimaFlow fan and VentilationJet

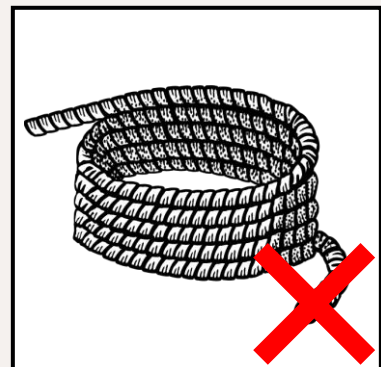
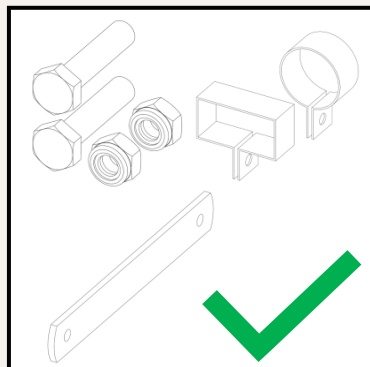
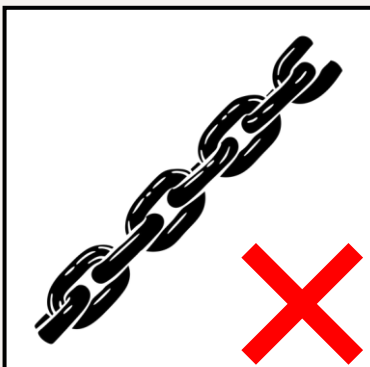

Operations

- Never use the fan at voltages, temperatures, or any other parameters exceeding those given in the product specifications. Otherwise, it might result in substandard performance, failure, fire, bodily injury, or electrical shock.
- Using a power supply with insufficient capacity might result in faulty fan operation because an inrush current several times larger than the rated current will flow at the moment of fan startup. Be sure to use a power supply with sufficient capacity.
- Never connect or disconnect lead wires, plug cords, or connectors while the power is on. Be sure to connect or disconnect them while holding the frame only after power-off. Otherwise, it might result in fan damage or electrical shock.
- Do not remove the nameplate.
- The fan might be damaged or burned out if foreign objects or external forces hinder normal fan operation.
- Do not use the power supply's PWM to control the speed of the fan. Doing so might result in fan malfunction.
- Turning the power on and off frequently or turning the power back on before the fan comes to a complete stop might result in fan failure or damage.
- The IP ratings apply only to the live electric parts and motor coils of the fan. The protection does not apply to the non-live parts of the fan.
- Do not wash the fan if any IP rated parts of the fan/jet is open. Doing so might result in failure of the fan.

Installation

- Install and secure the fan/jet properly with its weight and vibration during operation taken into account. Failure to do so might result in bodily injury or equipment failure due to the fan/jet falling off.
- Ensure that the fan/jet is installed in the right orientation. Failure to do so might result in bodily injury or equipment failure.
- For the fan/jet to perform to its full capacity, secure air vents and take measures to prevent foreign objects from entering the fan. Failure to do so might result in bodily injury or fan failure.
- Do not subject the fan/jet to excessive shock. Doing so might result in failure or substandard performance of the fan.
- Pulling or pinching lead wires might result in damage and stress to the wire. Also, make connections so that the lead wires do not come into contact with the rotating blades. Failure to do so might result in equipment failure or electrical shock.
- Take proper precautions against static electricity when wiring. Failure to do so might cause failure of the fan/jet or equipment.
- Make connections correctly in accordance with the information of this Product Specification and the nameplate of the fan/jet. Failure to do so might result in equipment failure or the malfunction, failure, or performance degradation of the fan/jet..
- When mounting the fan with screws, ensure that the screw tightening torque is correct. If the tightening torque exceeds the recommended torque, the fan/jet might be deformed or damaged.

Use screws and bolts that are provided in the delivery. Failure to do so might result in failure or loose fan/jet, which could lead to performance decrease and the fan/jet to fall down onto the ground. Beektech industries B.V are not responsible if the wrong bolts and or nuts have been used

Operating environments

Avoid using or storing the fan in the following environments. Otherwise, it might result in fire or the failure or performance degradation of the fan.

- Environments where flammable or corrosive gas is present
- Environments where water or oil splashes
- Environments where exposed to radioactive rays or direct sunlight
- Environments where a salty sea breeze blows or seawater splashes
- Environments where the fan might be contaminated by such corrosive materials as sulfurous water, sulfurous volcanic ash, organic solvents acidic and alkali chemicals, or nuclear fuel materials
- Environments where subjected to constant vibration, strong shocks, centrifugal force, acceleration, or strong magnetic force
- Environments where electromagnetic noise radiation is present, where the electromagnetic noise overlaps into power voltage
- Environments where subjected to rapid environmental fluctuations (temperature, humidity, pressure, etc.)

Storage

- The fan should be stored in the box it came in from Beektech Industries B.V.
- Ensure that the equipment is stored in the following environments where:
 - the temperature is between -10 and 45 °C and stable.
 - the relative humidity is between 20% and 85% with no sudden changes in humidity and no condensation
 - not subjected to direct sunlight
 - not subjected to water, oil, corrosive materials, or other hazardous substances;
 - not subjected to vibration or shock.

Maintenance

- Maintenance and inspections of the fan should be done by technically qualified personnel or someone with sufficient expertise; the personnel shall be assigned at your own discretion. Failure to use qualified personnel might result in fire, burns, bodily injury, or electrical shock.
- Never perform any maintenance or inspections while the fan is in operation. Also note that the blades continue to rotate for some time immediately after operation ceases. Always confirm that all rotating parts have stopped before starting work. Failure to do so might result in bodily injury.
- Never use gasoline, paint thinner, benzene, or any other organic solvents to clean the fan. Also, avoid placing excessive stress on the fan. Otherwise, it might result in product deformation or performance degradation

Lifting the VentilationJet

We highly advise using the following materials to lift the VentilationJet:

- 2x Petzl anneau sling 40cm
- 1x Super static 11mm (3x needed height)
- 3x Petzl OK Black – Triact lock
- 1x Petzl MGO 110
- 1x Petzl Micro Traxion
- 1x Petzl Mobile

Scan the QR-code for a step-by-step instruction video to lift the VentilationJet.



General description VentilationJet System

The ClimaFlow Fan facilitates vertical air movement, serving to supply fresh air to your plants and remove excess moisture. This optimization and creation of an active climate contribute to a happier plant. Since warm air is lighter than colder air, it accumulates at the top, and the fan can push it back down. This allows for the reuse of the introduced energy.

The VentilationJet is a fan positioned between the screen and attached to the truss. This setup enables the suction of additional (forced) outdoor air and its injection into the greenhouse. The use of more screen walls can limit crops and light radiation. It also results in significant energy savings and a more uniform climate. Sufficient reasons to employ more screens. With the VentilationJet, you can efficiently dehumidify the greenhouse using colder outdoor air (lower absolute humidity) while keeping the screen closed. Depending on the need and climate conditions, the VentilationJet's speed can be adjusted. With the VentilationJet, you can dehumidify with a closed screen, thus preventing moisture buildup around and among the crops.

The VentilationJet System combines the functionality of the ClimaFlow Fan and the VentilationJet to occur throughout the crop.

How to use the VentilationJet System the VentilationJet system offers a way to manage the airflow in a space. By Varying the 0-10Vdc voltage signal, the speed of the fan can be adjusted to create the optimal amount of displaced air.

Included with delivery

The VentilationJet System consists of the following items:



VentilationJet

Dehumidifier that is installed between the screen installation

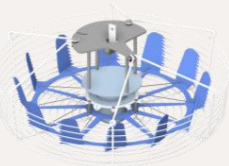

ClimaFlow Fan Type A

ClimaFlow fan that is placed on the bottom chord of the truss

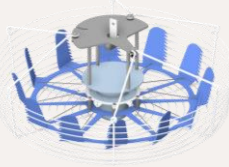

ClimaFlow Fan Type B

ClimaFlow fan that is attached underneath the VentilationJet

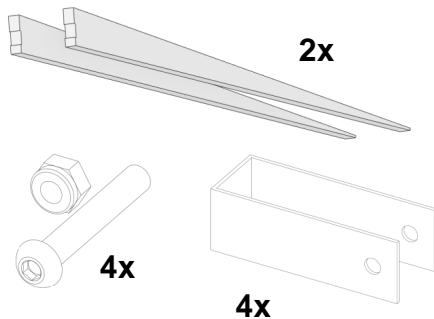

*Long Closing Strips

The long closing strips are attached to the VentilationJet to close the gaps between the screen profile and VentilationJet.

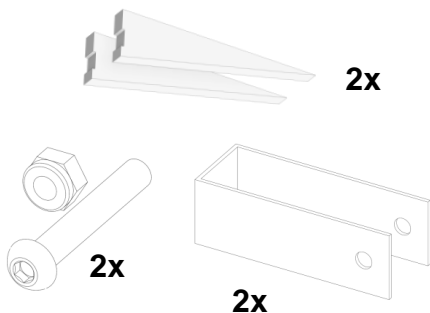

*Short Closing Strips

The long closing strips are attached to the VentilationJet to close the gaps between the screen package and VentilationJet.

* Quantity and bracket size delivered differs, depending on the screen installation and project agreements

Inside the box

The following items are included within the packaging of each ClimaFlow Fan

ClimaFlow Fan Type A

For placing directly on the truss

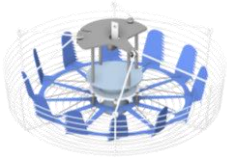

1x ClimaFlow Fan
Type A

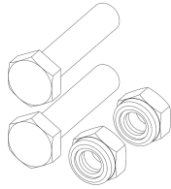

2x M8x40 bolts
+ locknuts

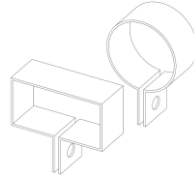

1x Truss clamp
(size differs)

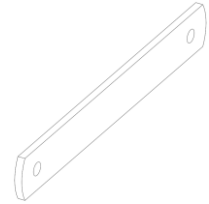

1x Extension strip
600mm

ClimaFlow Fan Type B

For placing underneath VentilationJet

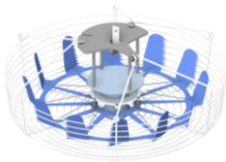

1x ClimaFlow Fan
Type B

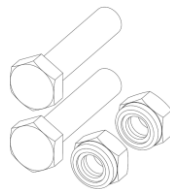

2x M8x40 bolts +
locknuts

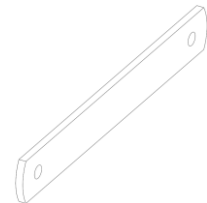

1x Extension strip
190mm



*Type B fans are
labeled on the box*

VentilationJet components



The VentilationJet

The VentilationJet is placed in between the screen installation to take in cold outside air inside the cultivation room.

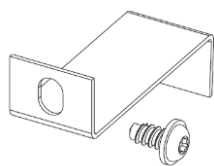

4x Truss clamps + screws

When the VentilationJet is placed on the truss, it's secured by 4 truss clamps and the plastic parker screws.



1x Bracket for ClimaFlow Fan suspension

This bracket is placed on the VentilationJet in order to place the ClimaFlow fan

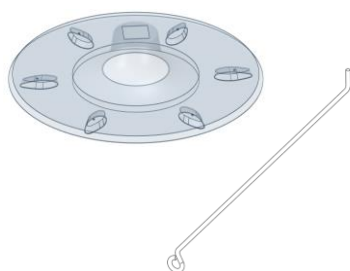

1x Air diffusion plate + 6x spokes

The air division plate is attached to the VentilationJet with the spokes, to distribute the air in the greenhouse

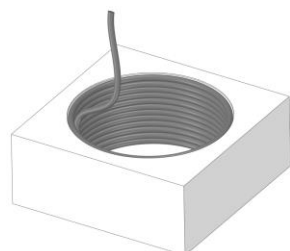

Water drain tube

Attached to the VentilationJet to drain excess water that condenses on the VentilationJet

Control cable

The ClimaFlow Fan and VentilationJet can be controlled with a 0-10v analog signal via the attached control cable. See diagrams A and B for instructions to control RPM via climate computer or a potentiometer.

The VentilationJet

RED = 10V OUT
 BLUE = GND
 YELLOW = 0-10V INPUT
 WHITE = TACHO

The ClimaFlow Fan

RED = 10V OUT
 BLUE = GND
 YELLOW = 0-10V INPUT
 WHITE = TACHO

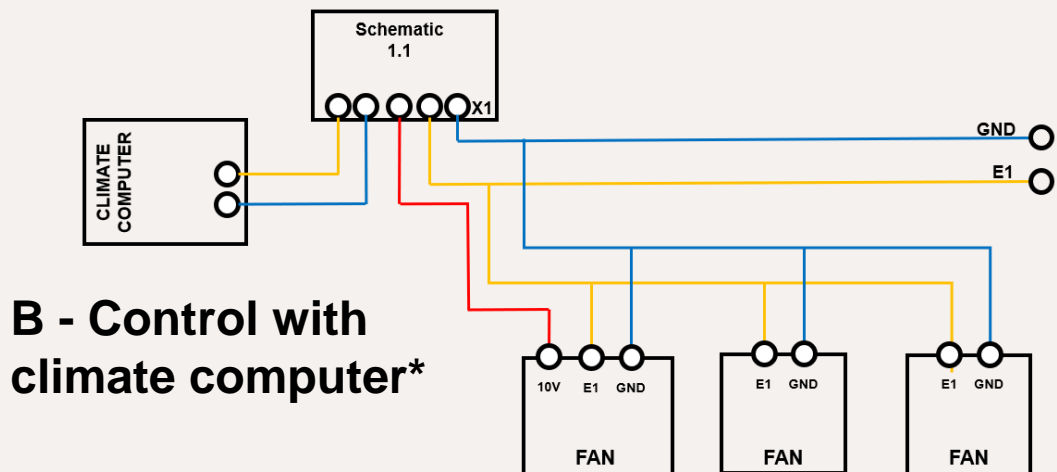
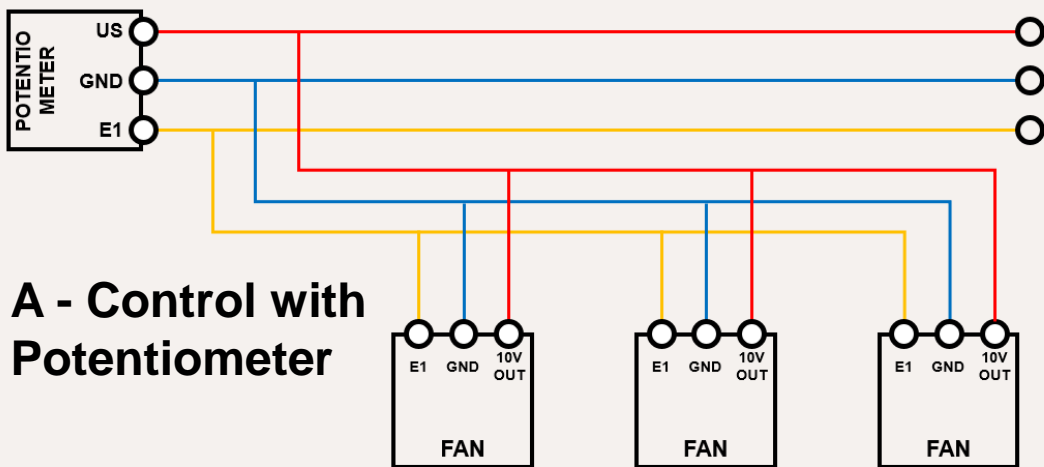

*Check you're ClimaFlow Fan for a harmonic filter. We suggest to not connect ClimaFlow Fan groups without a harmonic filter to be connected across three fases and one ground.

*For schematic 1.1, see page 36

Control cable

Make sure the yellow 0-10V wire is connected as showed in the diagram bellow inside the junction box of the VentilationJet

The VentilationJet

RED = 10V OUT
BLUE = GND
YELLOW = 0-10V INPUT
WHITE = TACHO

The ClimaFlow Fan

RED = 10V OUT
BLUE = GND
YELLOW = 0-10V INPUT
WHITE = TACHO

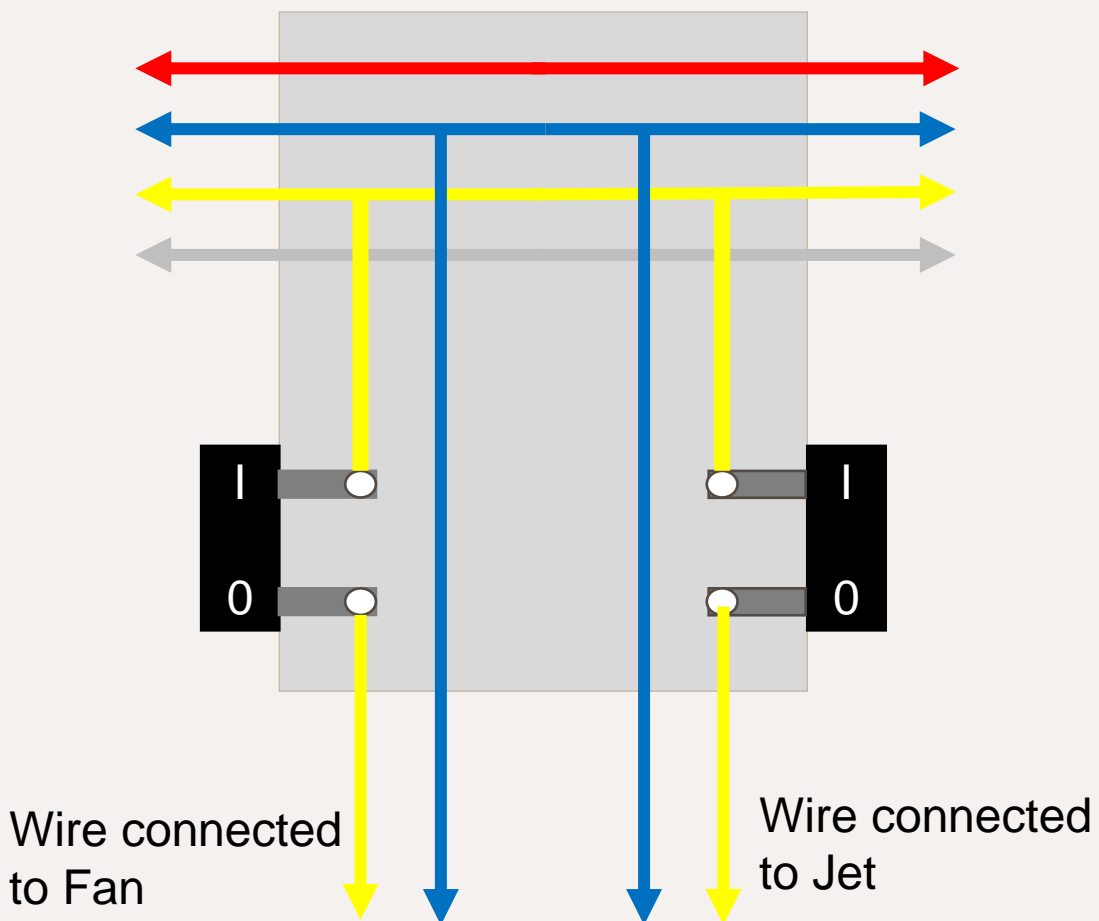

Power cables

The ClimaFlow system comes standard with one of the following power cable connections:



Wieland RST20i3 black

Manufacturer component no:
96.032.4053.1

(Also compatible with grey counterpart)



Wieland RST20i3 green

Manufacturer component no:
96.032.4055.7

(**Not** compatible with grey/black counterpart)



CEE 7/7 Connector



Maintenance switch

Placing the VentilationJet

**Follow the following steps backwards to disassemble the VentilationJet System*

Every VentilationJet is delivered nearly fully assembled. It can be placed on the truss with the brackets attached on the back

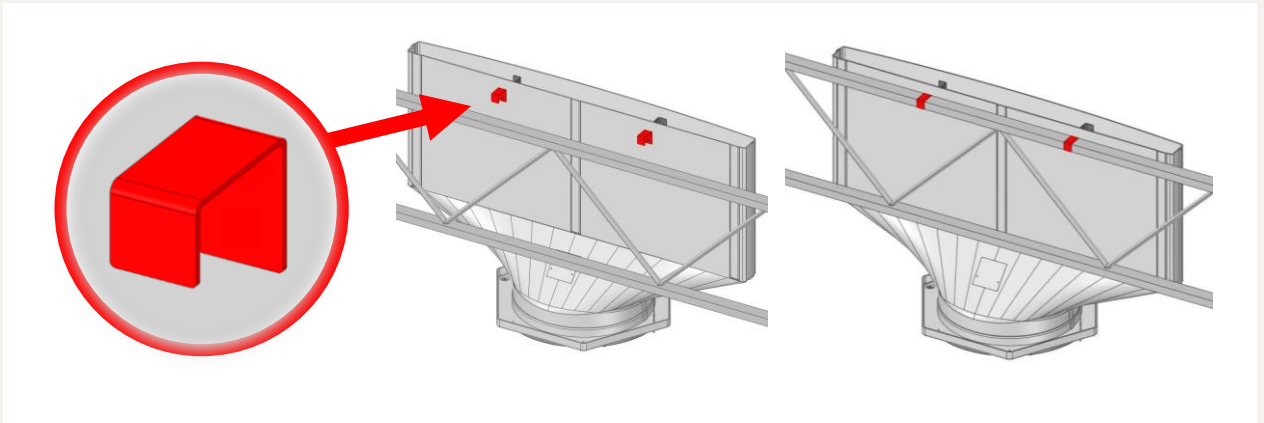

Secure the VentilationJet

Secure the Ventilation Jet by clamping it to the truss with the 4 truss clamps, and plastic screws

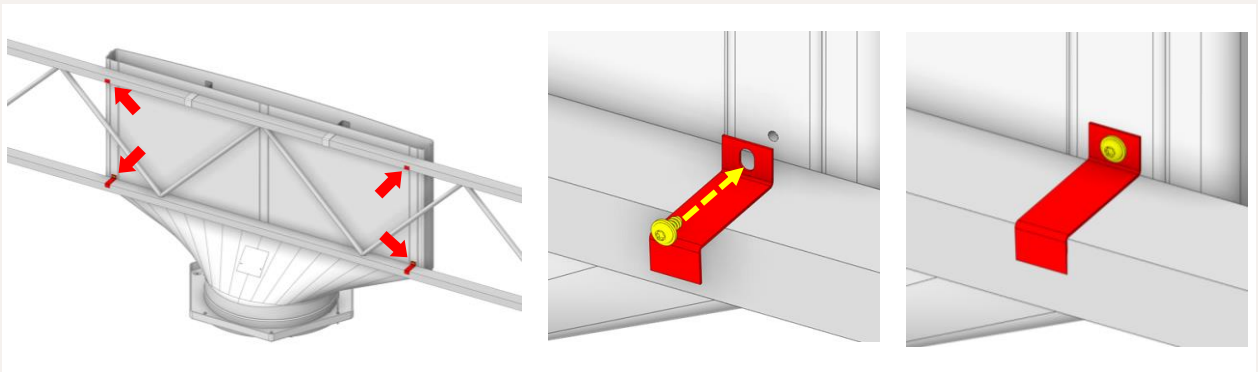

Closing strips

Depending on the screen installation that is present, short and/or long closing strips are delivered. Each short closing strip needs 1 bracket to be placed on the truss. Each long closing strip needs 2 brackets.

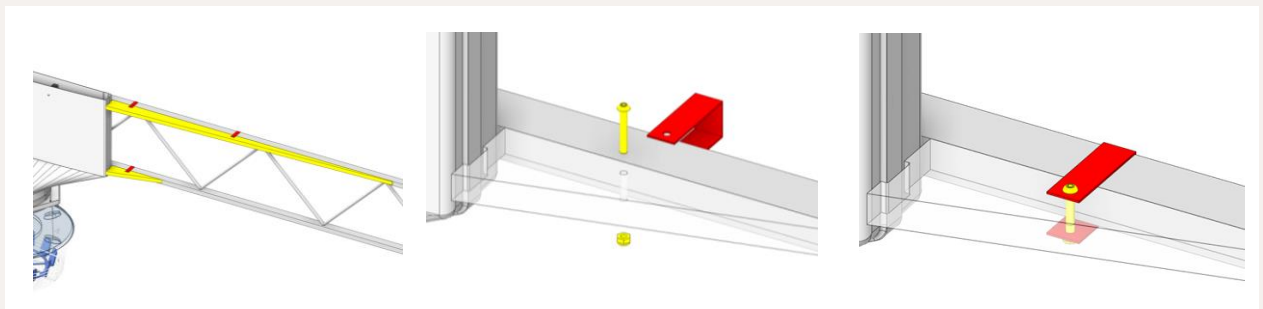

**Drill a hole for the m6 bolt to pass through the closing strip*

Closing strips*

The following closing strips can be delivered optionally.

Long closing strips

Placed where the screen profile closes towards the VentilationJet.
Per VentilationJet are two strips, 4 brackets, and 4 M6x40 bolts and nuts

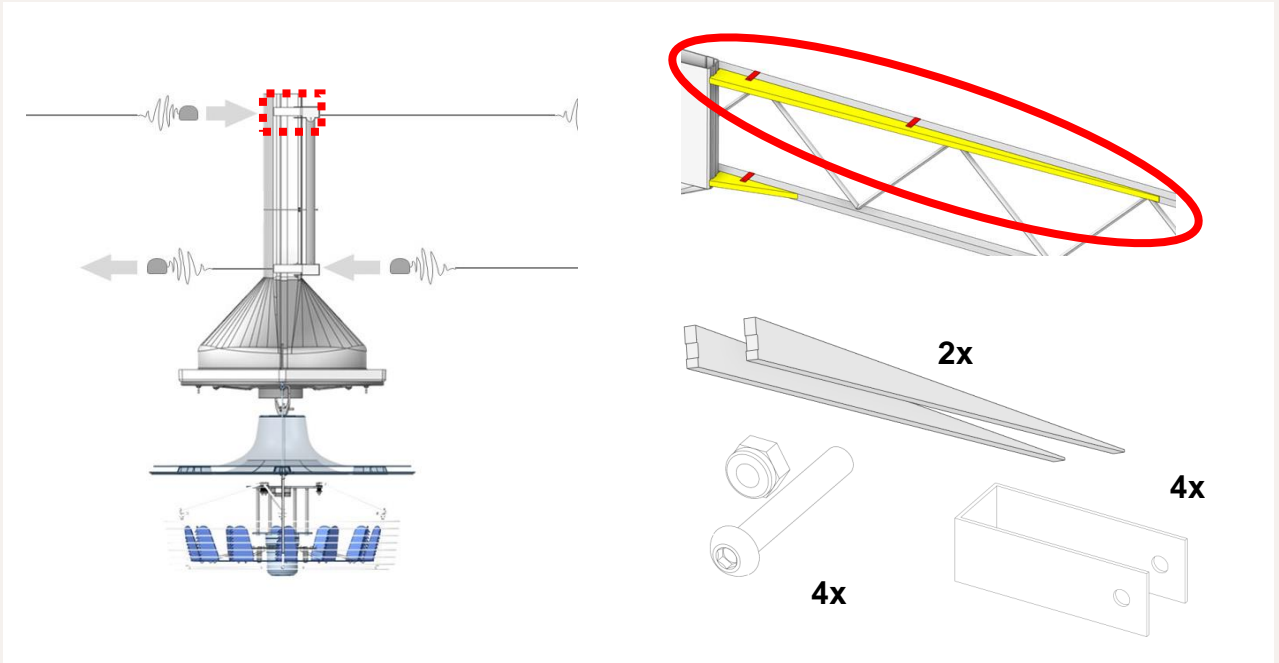

Short closing strips

Placed where the screen package closes around VentilationJet
Per VentilationJet are two strips, 2 brackets, and 2 M6x40 bolts and nuts

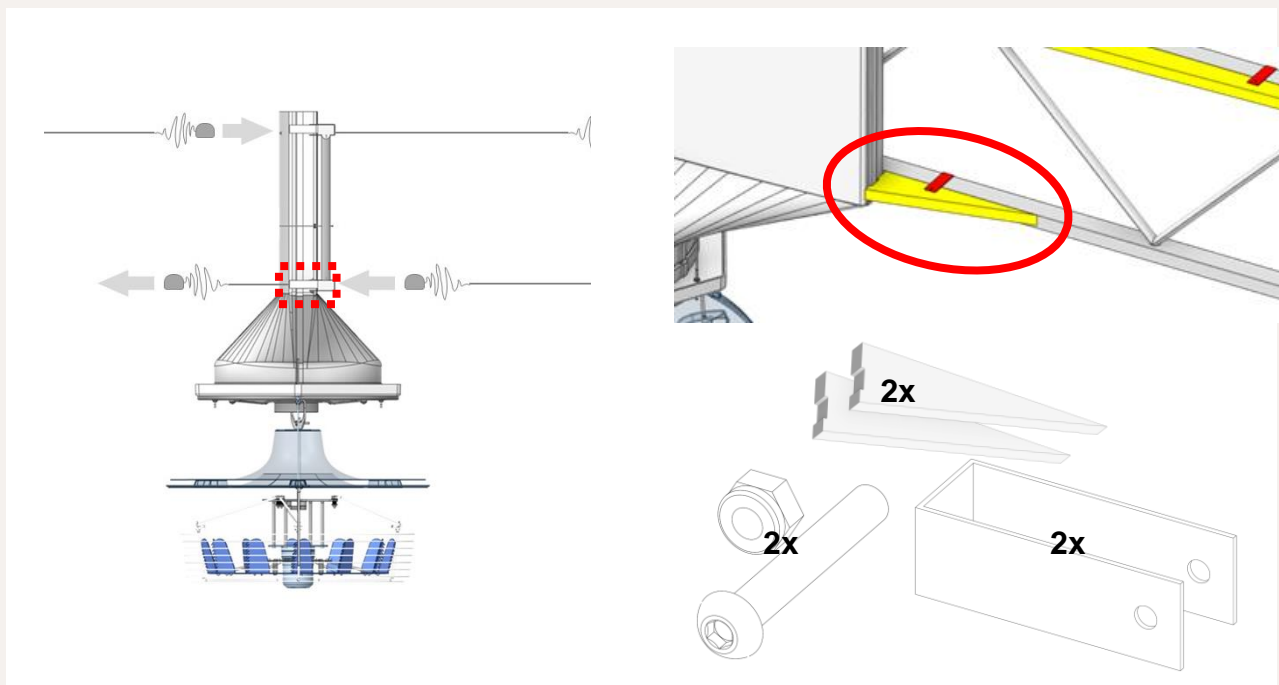

* Quantity and bracket size delivered differs, depending on the screen installation and project agreements

Spokes & Climaflow suspension

Attach the ClimaFlow bracket followed by the two spokes.

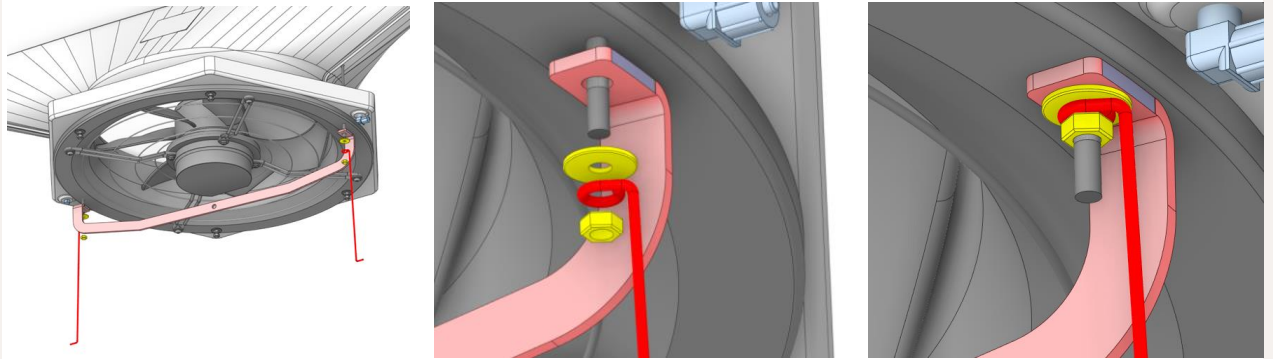

Next, attach the other four spokes with the already attached locknut.

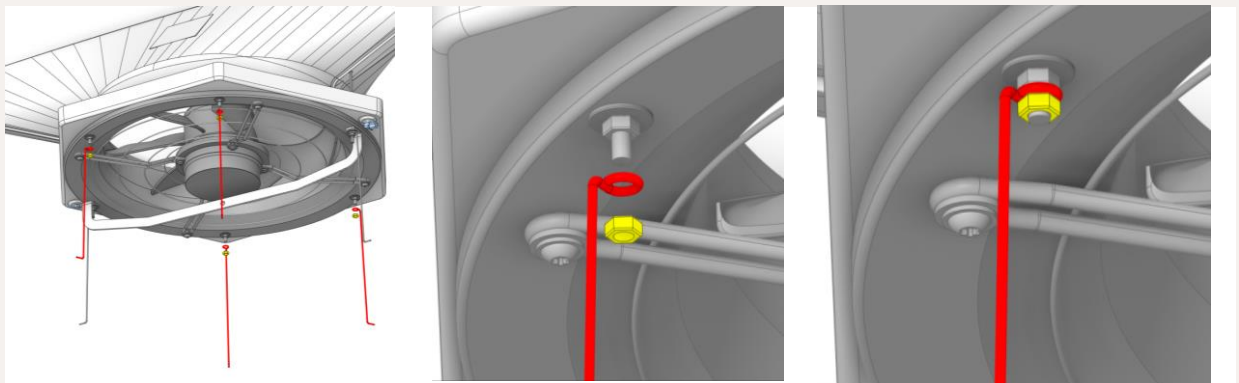

Place the transparent air plate on the spokes.

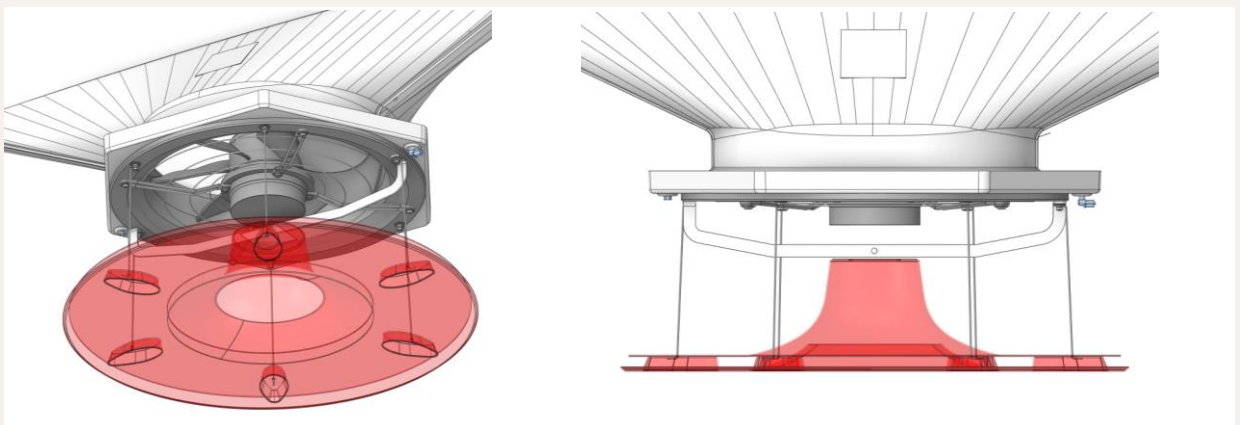

Placing Climaflow Fan type A

The Type A ClimaFlow fan needs to be installed directly to the truss. The truss-clamp, extension strip and fasteners are included in the packaging.

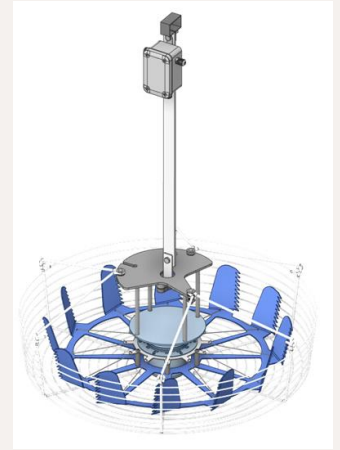

Attach the extension strip with the M8 fasteners.

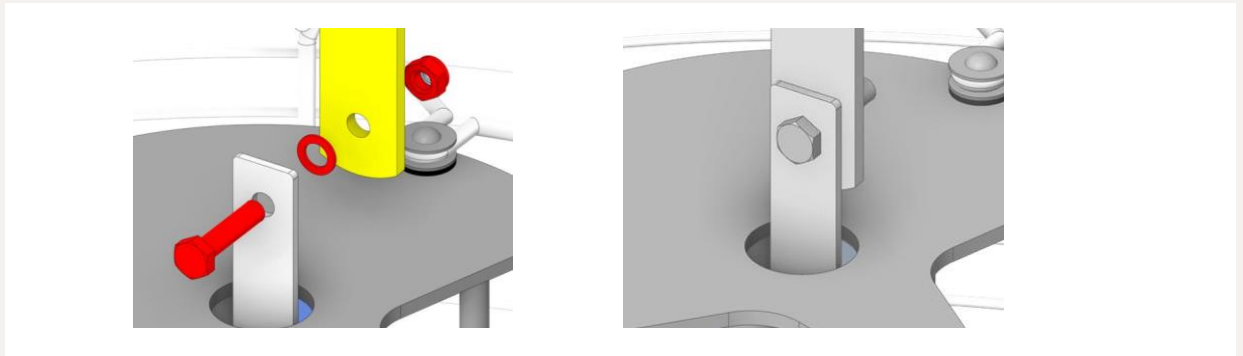

Attach the fan to the truss with the truss clamp. The junctionbox that holds the control cable is attached as well.

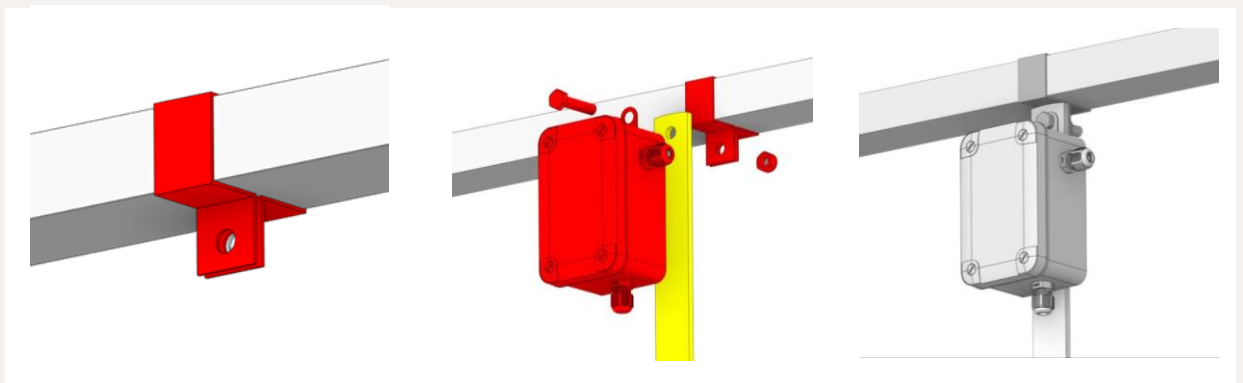

In the junction box are cable clamps included to connect the RPM control.



Placing Climaflow Fan type B

The Type B ClimaFlow fan needs to be installed underneath the VentilationJet. Fasteners are included in the box. All type B fans are marked by a sticker on every box.

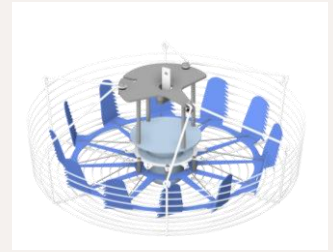

Attach the extension strip with the M8 fasteners.

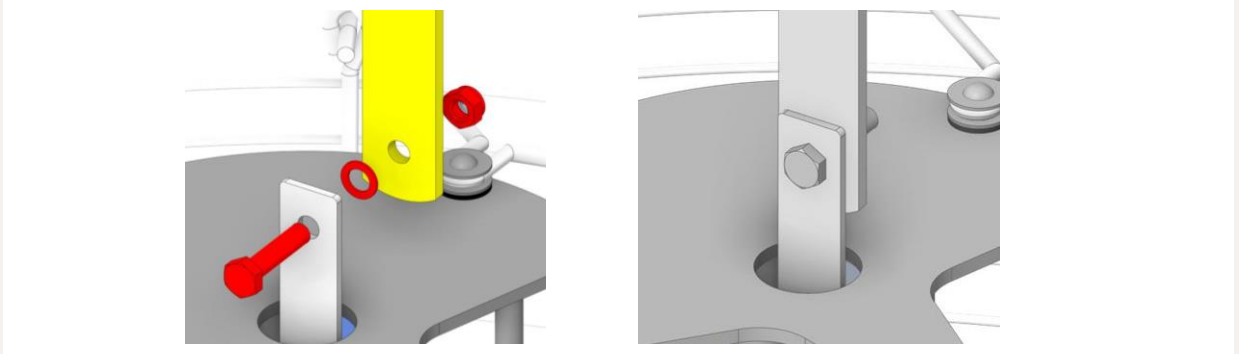

Attach the ClimaFlow Fan Type B to the VentilationJet by the Extension strip.

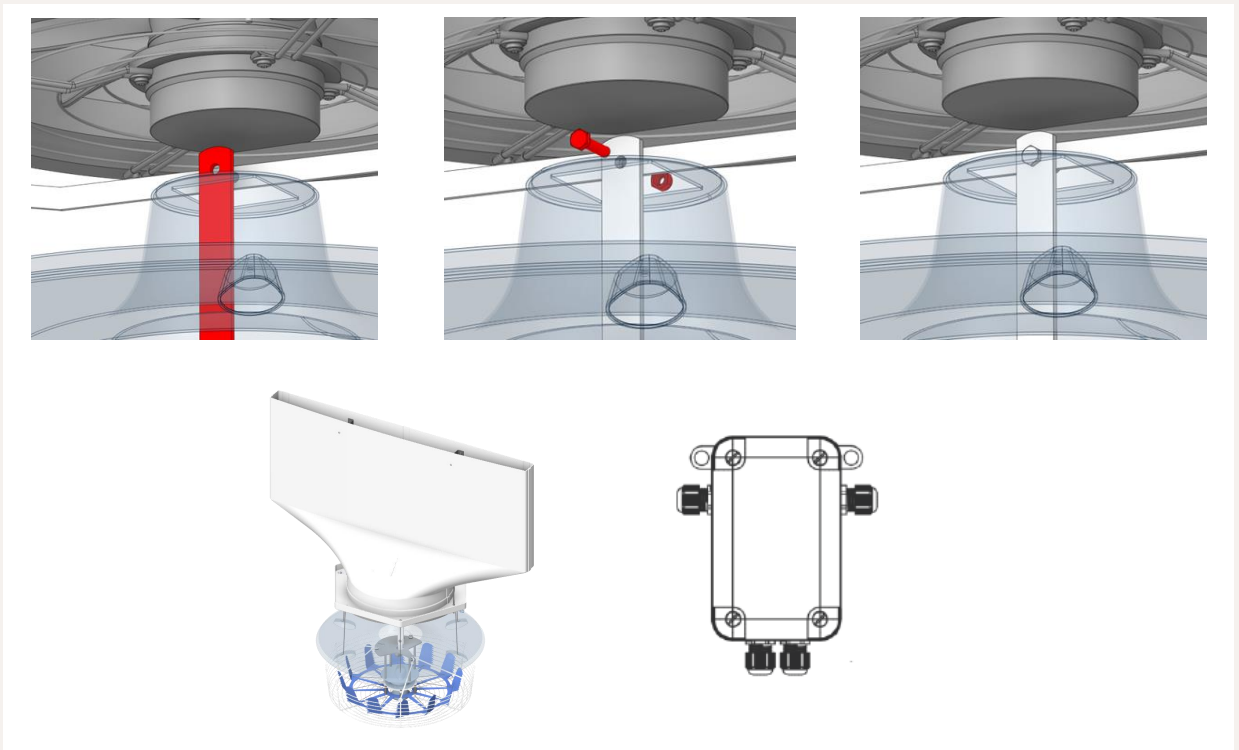

The ClimaFlow Fan control cable can be inserted in the VentilationJet junction box

Placing the ClimaFlow Fan cables

The Type B ClimaFlow fan needs to be installed underneath the VentilationJet. To ensure a safe installation of the VentilationJet system. Place the cables as followed.

Attach the cable holders to the extension strip.

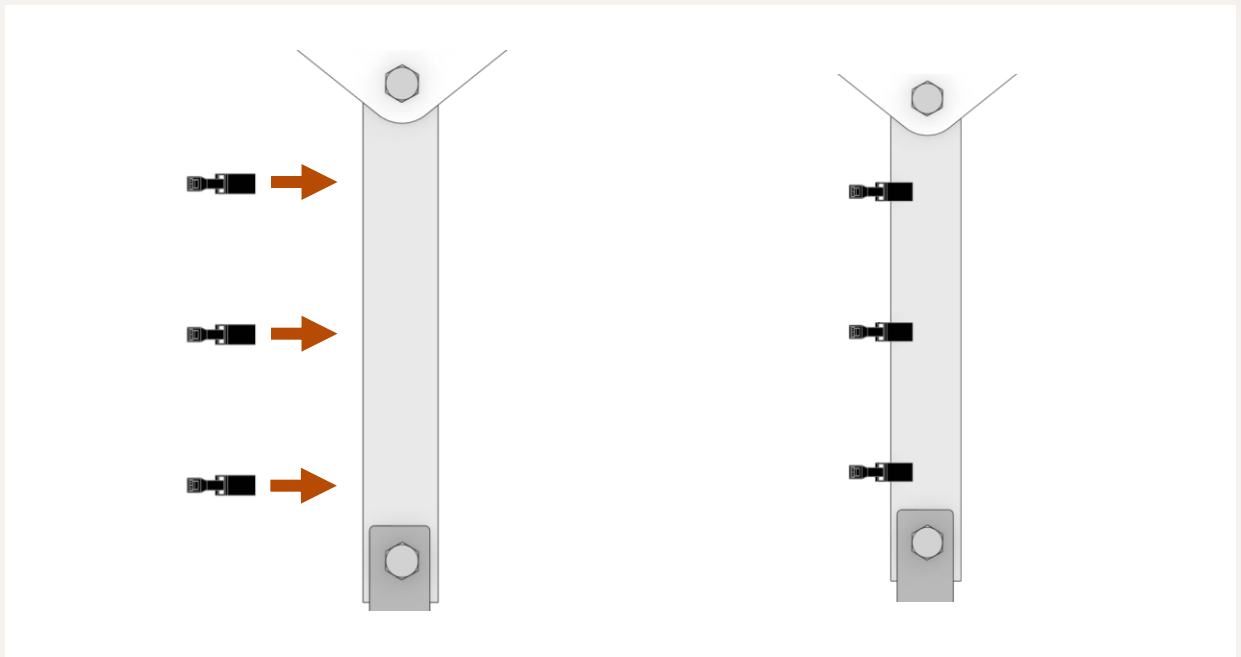

Attach the ClimaFlow Fan Cable to the cable holders with the provided zip ties. Attach the cable on the bottom of the ventilation jet motor as shown bellow

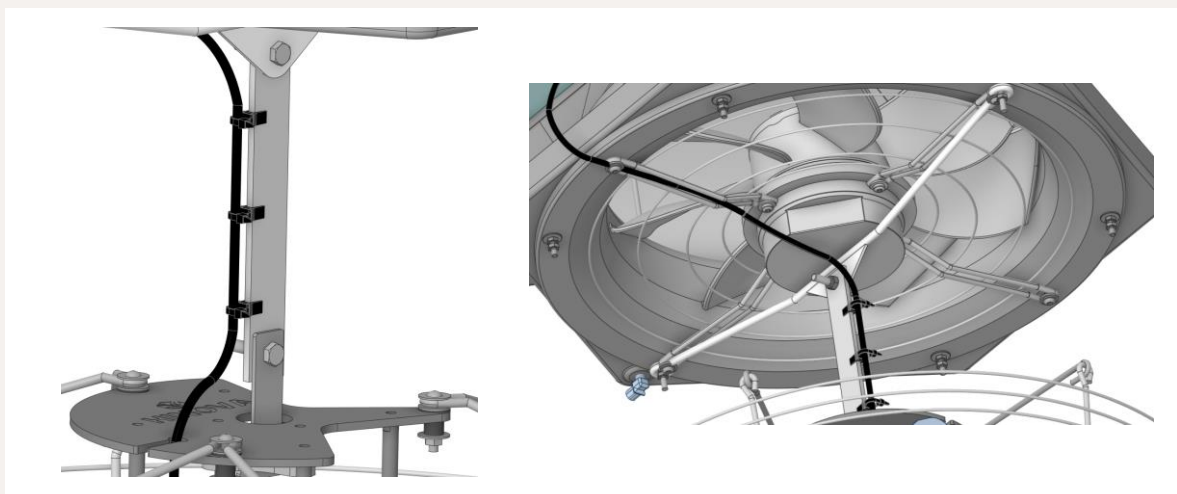

**Make sure the cable isn't in contact with any metal parts.*

Maintenance protocol

- Under no circumstances use a pressure washer or jet water for cleaning.
- To prevent unwanted moisture, it is advisable to tighten any cable glands before cleaning.
- Check if the cables at the gland make a slight bend downward before going up towards the cable tray. This ensures that no condensation drops run towards the glands.
- The entire ventilator can be cleaned with a damp cloth.
- After the cleaning process, the motor should run at 80-100% of the maximum RPM for 30 minutes to allow any possibly infiltrated water to evaporate.
- Check, in the case of a Ventilation Jet system®, if the edge of the casing is clean, and that the water drainage hose is still running smoothly.
- During longer periods of inactivity in a humid atmosphere, it is recommended to operate the fans for at least 2 hours monthly to allow any infiltrated moisture to evaporate.
- Finally, check whether the white basket is correctly attached to the designated hooks.

Unblocking an obstructed fan blade

To unblock a VentilationJet or ClimaFlow fan, always consult the manual to determine the required Personal Protective Equipment (PPE) before working on the VentilationJet and ClimaFlow fan.

- **Check PPE**
Consult the manual to identify the necessary Personal Protective Equipment and wear it before starting.
- **Turn off the VentilationJet System**
Stop the VentilationJet System by setting the control signal to 0 V and turning off the switch on the fan's junction box.
- **Disconnect the plug**
Unplug the power plug of the fan to ensure electrical safety.
- **Remove the obstruction**
Identify and remove the object blocking the fan.
- **Reconnect the plug**
Plug the fan back into the outlet, ensuring a secure and correct connection.
- **Restore control power**
Set the control power back to the desired voltage and turn the switch on the junction box back on.
- **Press the Start button**
To start the recently stopped ClimaFlow Fan locate the start button and press it to restore normal fan operation.

By following these steps, you can unblock the ClimaFlow fan and ensure it functions properly again.

Datasheet VentilationJet (VJ-45EU)

The VentilationJet® is designed for mixing air from above the screens into the greenhouse. This document includes the fan specifications.

Specifications

Description

VentilationJet

Line Voltage	1~ 200-277V 50/60Hz P1 390W 1,95-1,4A
Rated values	EC 1470rpm 60°C IP54, THCL 155
Motor	cRUus UL Recognized Component
Power connection out	Incl. power cable 2M
Electrical connection	Integrated Controller
Adjustable control	A variable speed drive is integrated within the fan. It's controlled by a 0-10Vdc signal. 100K Ω
Motor protection	Integrated active temperature management
Min. operating Temperature (°C)	-35
Bearing quality	Ball bearing with long-time lubrication
Color of rotor	Marine blue
Material rotor	Steel
Color of blade	Black
Material of inlet	ABS/PMMA
Protection	Incl.
Weight	12 KG / 26.4 lb.
Harmonics	The VentilationJet does include a Harmonic filter.
Sound	The VentilationJet System creates 79 Decibels and 150 Pa static pressure at 1470 RPM

Power consumption

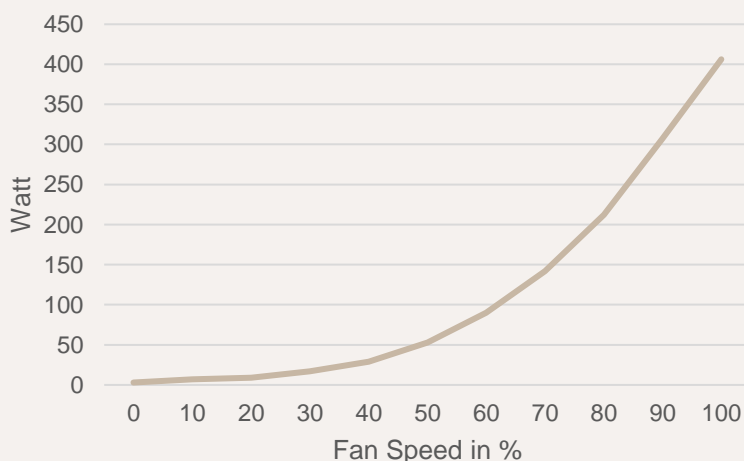

Datasheet ClimaFlow Fan

Type: ClimaFlow Fan 1 (CF-H800)

The VentilationJet® is designed for mixing air from above the screens into the greenhouse. This document includes the fan specifications.

Specifications

Line Voltage	1~ 200...277V, 50/60Hz 195W, 1.0A
Leakage	<8 mA. At 230V 50/60Hz.
In rush Current	15,2 A
Rated values	EC electronically limited. IP54.
Power connection out	2M power cable
Electrical connection	integrated controller
Adjustable control	A variable speed drive is integrated within the fan. It's controlled by a 0-10Vdc signal. Input resistance 10K Ω
10V output	5 mA
Working temperature	-25~+60

Bearing	HCH 6001Z deep groove ball bearing single row
Color of rotor	Black
Material rotor	Steel
Quality of the blade	Vanes equipped with quiet technology
Color of blade	Blue
Material blade	Aluminum
Material of construction	Stainless steel / Aluminum
Material of mounting strip	Galvanised steel
Material of basket	Galvanised steel with powder coating

Protection	Basket surrounds the spinning blade
Suspension system	Mounting strip and truss bracket
Control area	approx. 256M2/2700sqft per fan
0-10V output	Voltage is supplied by the motor for external devices.
Sound	The ClimaFlow Fan produces 70 DB
Weight	
Harmonics	The ClimaFlow Fan does not include a Harmonic filter Fan groups can not be connected across three phases and one ground

Weight 8.9KG/19.6 lb

Power consumption

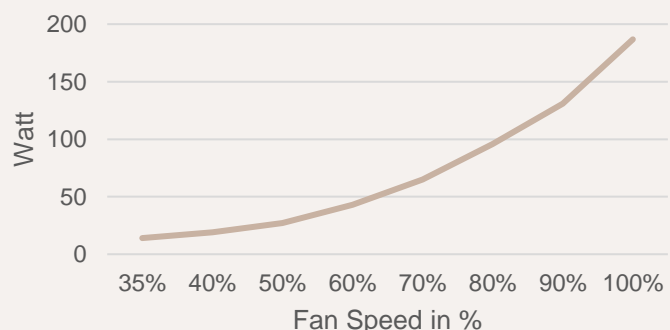

Datasheet ClimaFlow Fan AC

Type ClimaFlow Fan 2 (CF-AC85)

The VentilationJet® is designed for mixing air from above the screens into the greenhouse. This document includes the fan specifications.

Specifications

Line Voltage	1~MOT 230V ±10% 50Hz P1 260W 1,2A 1~MOT 230V ±10% 60Hz P1 300W 1,3A
Rated values	IP54 THCL 155
Power connection out	2 meter power cable electrical connection
Terminal box	K05 (fixed on motor)
Control	On/Off (RPM Controllable with external controller)
Motor Protection	Thermal contact
Min. operating Temperature (°C)	-35

Bearing quality	Ball bearing with long time lubrication
Color of rotor	Black
Material rotor	Steel
Color of blade	Blue
Material blade	Aluminum
Material of construction	Stainless steel
Material of mounting strip	Galvanized steel
Material of basket	Galvanized steel – White powder coating

Protection	Incl. Basket
Suspension system	Mounting strip and truss bracket.
Control area	Each fan has a control area of approx. 256 m ³ / 2700 sqft
Weight	6,7 KG
Sound	The CLimaFLow fan produces 68 DB

Power consumption

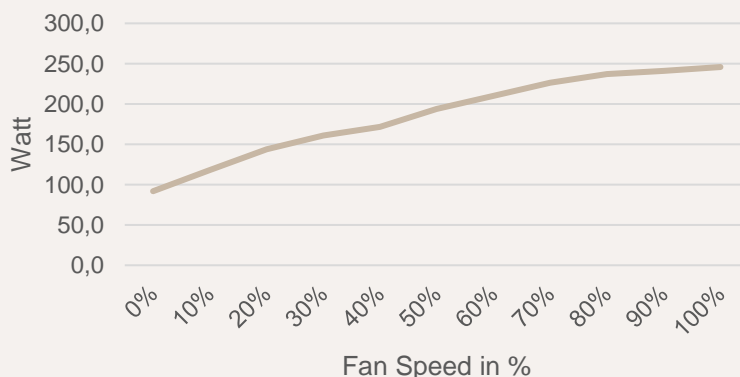

Datasheet ClimaFlow Fan

Type: ClimaFlow Fan 3 (CF-EC72)

The VentilationJet® is designed for mixing air from above the screens into the greenhouse. This document includes the fan specifications.

Specifications

Line Voltage	1 ~ 200...240Vac, 50/60Hz, P1 130W, 1,15-1,4A
Rated values	60°C IP54 THCL 155
Motor	cRUus UL Recognized Component
Power connection out	Incl, Power cable 2M
Control	A variable speed drive is integrated within the fan. It's controlled by a 0-10Vdc signal.
Motor Protection	Integrated active temperature management
Min. operating Temperature (°C)	-35

Bearing quality	Ball bearing with long time lubrication
Color of rotor	Marine Blue
Material rotor	Steel
Color of blade	Blue
Material blade	Aluminum
Material of construction	Stainless steel
Material of mounting strip	Galvanized steel
Material of basket	Galvanized steel – White powder coating

Protection	Incl. Basket
Suspension system	Mounting strip and truss bracket.
Control area	Each fan has a control area of approx. 256 m ³ / 2700 FT ²
Sound	The ClimaFlow Fan produces 68 DB
Weight	6,7 KG
Harmonics	The ClimaFlow Fan does not include a harmonic filter. ClimaFlow Fan groups must not be connected across three phases and one ground.

Power consumption

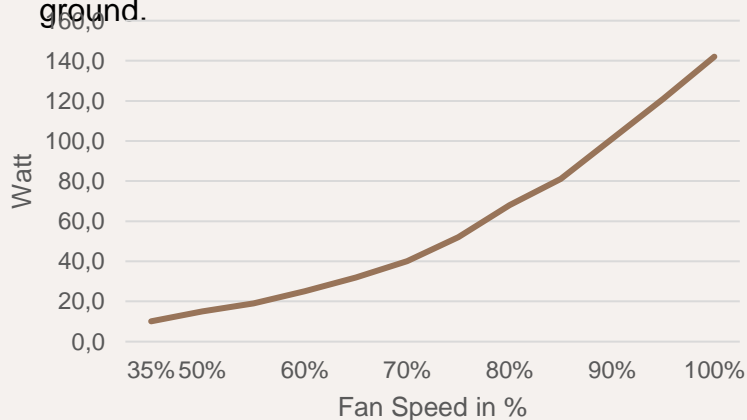

Datasheet ClimaFlow Fan

Type ClimaFlow Fan 4 (CF-EC90)

The VentilationJet® is designed for mixing air from above the screens into the greenhouse. This document includes the fan specifications.

Specifications

Line Voltage	1 ~ 200...277Vac, 50/60Hz, P1, 390W, 1.4-1,95A
Rated values	EC 850 RPM 60°C, IP54, THCL 155
Motor	cRUus UL Recognized Component
Power connection out	Incl. Power cable 2M
Electrical connection	Integrated controller
Adjustable control	A variable speed drive is integrated within the fan. It's controlled by a 0-10Vdc signal.
Motor protection	Integrated active temperature management
Min. operating Temperature (°C)	-35

Bearing quality	Ball bearing with long-time lubrication
Color of rotor	Marine blue
Material rotor	Steel
Color of blade	Blue
Material of blade	Aluminum
Material of construction	Stainless steel
Material of mounting strip	Galvanized steel
Material of basket	Galvanized steel + white powder coating

Weight	8,7 Kg
Harmonics	The ClimaFlow Fan does include a harmonic Filter
Sound	The CLimaFLow Fan produces 70 Db

Power consumption

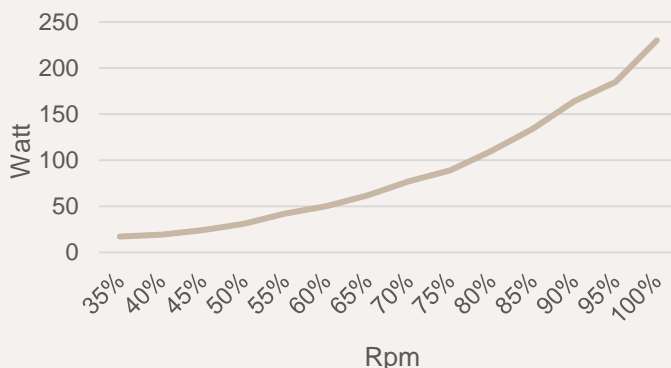

Fan efficiency

VentilationJet: (VJ-45EU)

Airflow	Value	Unit
40% of max rpm	2450	M ³ /h
60% of max rpm	3920	M ³ /h
80% of max rpm	5450	M ³ /h
90% of max rpm	6180	M ³ /h
100% of max rpm	7150	M ³ /h

Max air pressure: 280 Pa

Power consumption	Value	Unit
40% of max rpm	34	W
60% of max rpm	92	W
80% of max rpm	200	W
90% of max rpm	300	W
100% of max rpm	430	W

Most efficient operation: 70-100% of max rpm.

η target = 50,3%

η VJ45 = 58,87%

Fan efficiency

ClimaFlow Fan 1: (CF- H800)

Airflow	Value	Unit
40% of max rpm	2740	M ³ /h
60% of max rpm	4100	M ³ /h
80% of max rpm	5820	M ³ /h
90% of max rpm	6840	M ³ /h
100% of max rpm	7530	M ³ /h

Max air pressure: 151 Pa

Power consumption	Value	Unit
40% of max rpm	19	W
60% of max rpm	43	W
80% of max rpm	96	W
90% of max rpm	131	W
100% of max rpm	187	W

Most efficient operation: 65-100% of max rpm.

η target = 48,0%
 η H800 = 75,55%

Fan efficiency

ClimaFlow Fan 2: (CF-AC85)

Airflow	Value	Unit
40% of max rpm	2730	M ³ /h
60% of max rpm	3620	M ³ /h
80% of max rpm	5130	M ³ /h
90% of max rpm	5180	M ³ /h
100% of max rpm	6150	M ³ /h

Max air pressure: 83 Pa

Power consumption	Value	Unit
40% of max rpm	92	W
60% of max rpm	161	W
80% of max rpm	226	W
90% of max rpm	241	W
100% of max rpm	246	W

Most efficient operation: 100% of max rpm.

η target = 48,8%

η AC85 = 31,2%

Fan efficiency

ClimaFlow Fan 3: (CF-EC72)

Airflow	Value	Unit
40% of max rpm	2730	M ³ /h
60% of max rpm	3830	M ³ /h
80% of max rpm	5130	M ³ /h
90% of max rpm	5810	M ³ /h
100% of max rpm	6840	M ³ /h

Max air pressure: 114 Pa

Power consumption	Value	Unit
40% of max rpm	10	W
60% of max rpm	32	W
80% of max rpm	68	W
90% of max rpm	101	W
100% of max rpm	142	W

Most efficient operation: 70-100% of max rpm.

η target = 47,2%

η EC72 = 75,4%

Fan efficiency

ClimaFlow Fan 4: (CF-EC90)

Airflow	Value	Unit
40% of max rpm	2740	M ³ /h
60% of max rpm	4100	M ³ /h
80% of max rpm	5820	M ³ /h
90% of max rpm	6840	M ³ /h
100% of max rpm	7530	M ³ /h

Max air pressure: 151 Pa

Power consumption	Value	Unit
40% of max rpm	19	W
60% of max rpm	50	W
80% of max rpm	89	W
90% of max rpm	134	W
100% of max rpm	185	W

Most efficient operations: 65-100% of max rpm.

η target = 48,6%

η EC90 = 75,4%

Electrical connection diagrams (Climate computer)

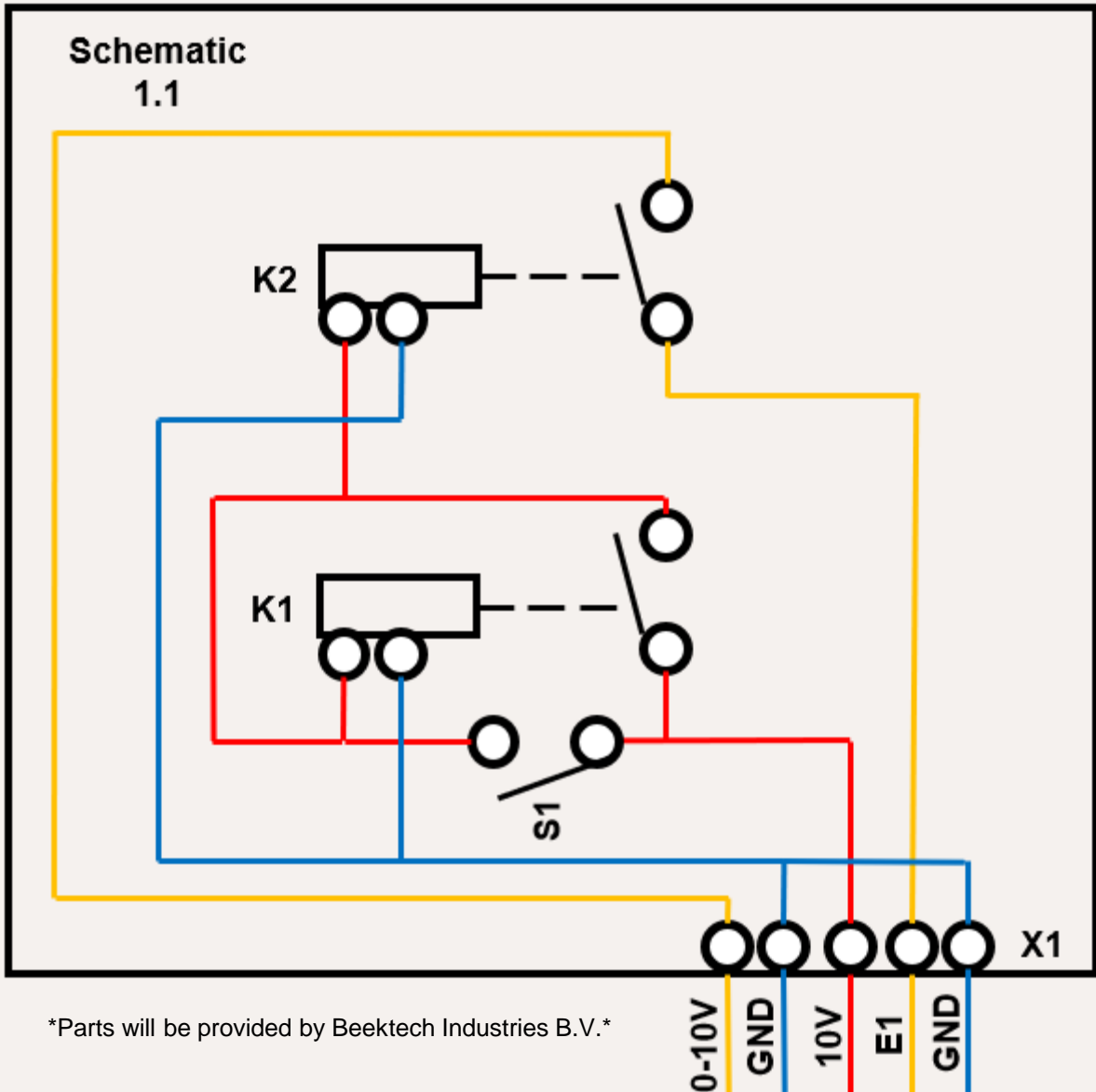

General Dimensions

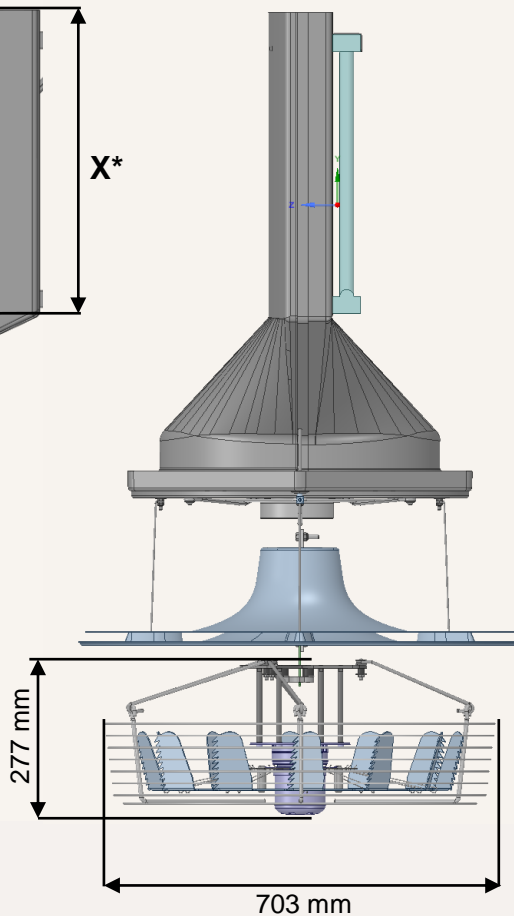
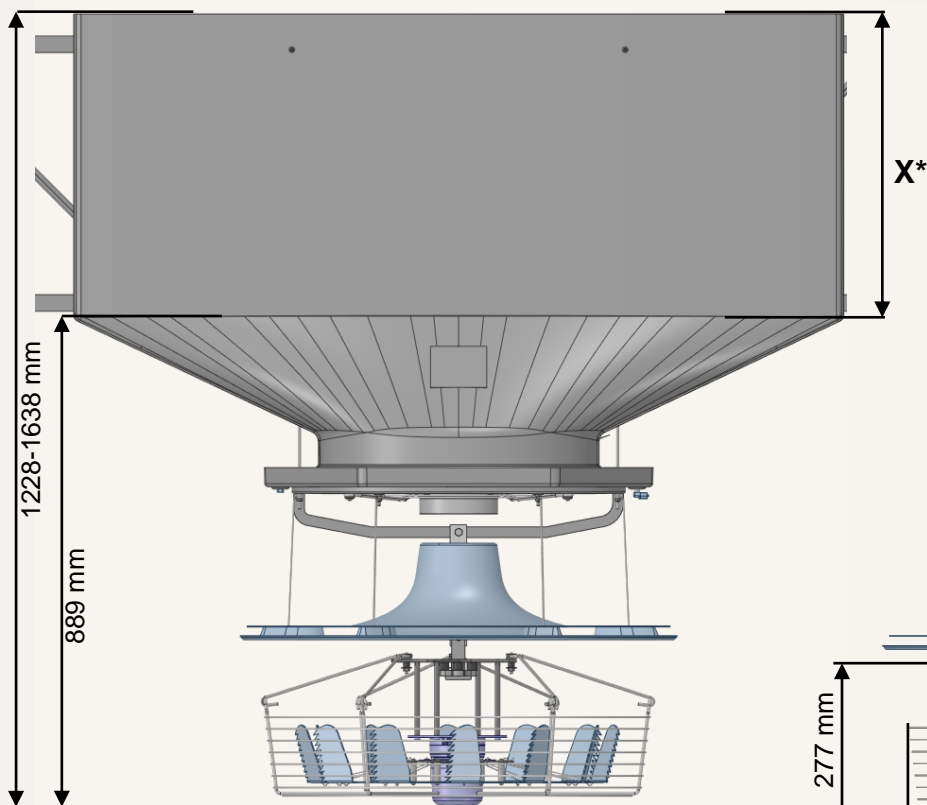
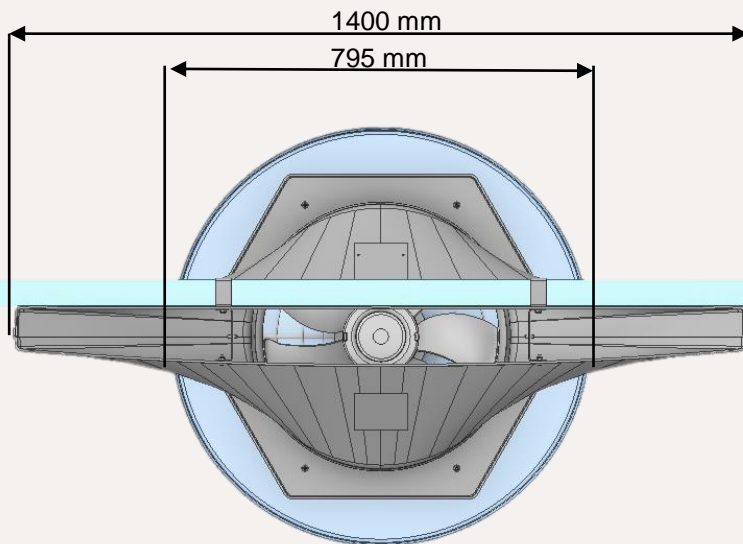

*X differs per VentilationJet as it depends on the truss size of the greenhouse construction.

EC DECLARATION OF CONFORMITY (No. 2023/386-01)

This Declaration of Conformity is issued under the sole responsibility of the manufacturer

MANUFACTURER

Company name	Beektech industries B.V.
Full address	Marconistraat 22-24, 2665 JE Bleiswijk
Country	The Netherlands
Identification of the person authorised to compile the Technical File	Mr. S. Rietdijk

DESCRIPTION AND IDENTIFICATION OF THE MACHINERY

Generic denomination	VentilationJet System
Function/Intended use	Facilitating vertical air movements
Models	VJ-FN45EU + H800, VJ-FN45EU + EC72
Type	Ventilationjet Systeem
Serial number	13000000 until 13999999
Commercial name	VentilationJet System

The object of the Declaration described above is in conformity with all relevant provisions of

**Machinery Directive 2006/42/EC; EMC Directive 2014/30/EU;
RoHS Directive 2011/65/EU ; Ecodesign 2009/125/EC**

In conjunction with the following relevant harmonised standards or technical specifications

EN-ISO 12100; EN-IEC 63000:2018; (EU) No 327/2011

Signed for and on behalf of

Place of issue: Bleiswijk, **Identity:** Mr. S. Rietdijk
The Netherlands **Function:** General manager

Date of issue: 4/06/2024 **Signature:**

Now it's time to grow with the flow.
ClimaFlow

**For questions, please contact your
nearest Svensson office**

**United States/Canada
Ludvig Svensson Inc.
+1 704 357 0457
info.us@ludvigsvensson.com**

**Netherlands
Ludvig Svensson BV
+31 181 39 26 66
info.nl@ludvigsvensson.com
Stefan Rietdijk**



The ClimaFlow Fans and VentilationJets are manufactured
by Beektech Industries B.V. – a Svensson company
Marconistraat 22-24, 2665 JE Bleiswijk, Netherlands